



Say yes to solar power! Because it protects the climate.

Innovations from a photovoltaic pioneer

As a solar specialist with more than 50 years of experience in photovoltaics (PV), Sharp makes significant contributions to groundbreaking progress in solar technology.

Sharp photovoltaic modules in the NU series are designed for applications with high power requirements. These quality monocrystalline modules produce a continuous, reliable yield, even under demanding operational conditions.

All Sharp NU series modules offer system integration which is optimal both technically and economically, and are suitable for installations in on and off-grid PV systems.



Product features

- High-performance photovoltaic modules made of monocrystalline (156.5 mm)² silicon solar cells with module efficiencies of up to 15.2%.
- Anti-reflex coating to increase light absorption.
- Production controlled positive power tolerance from 0 to +5%. Only modules will be delivered that have the specified power or more for high energy yield.
- Delivery of modules in 5-watt intervals.
- Improved temperature coefficient to reduce power losses at higher temperatures.
- High power performance even at lower irradianations.

Quality from Sharp

Benchmarks are set by the quality standards of Sharp Solar. Continual checks guarantee a consistently high level of quality. Every module undergoes visual, mechanical, and electrical inspection. This is recognisable by means of the original Sharp label, the serial number, and the Sharp guarantee:

- 5-year product guarantee
- 10-year performance guarantee on a power output of 90%
- 25-year performance guarantee on a power output of 80%

The detailed guarantee conditions and additional information can be found at www.sharp.eu/solar.

Certificates and approvals

All modules are tested and certified according to

- IEC/EN 61215 and IEC/EN 61730, Application class A
- Safety class II
- CE

Sharp is certified based on

- ISO 9001:2008 and ISO 14001:2004

Electrical data (at STC)

		NU-R250J5	NU-R245J5	NU-R240J5	
Maximum power	P_{max}	250	245	240	W_p
Open-circuit voltage	V_{oc}	37.9	37.5	37.3	V
Short-circuit current	I_{sc}	8.76	8.73	8.63	A
Voltage at point of maximum power	V_{mpp}	31.0	30.5	30.2	V
Current at point of maximum power	I_{mpp}	8.07	8.04	7.95	A
Module efficiency	η_m	15.2	14.9	14.6	%

STC = Standard Test Conditions: irradiance 1,000 W/m², AM 1.5, cell temperature 25 °C.
 Rated electrical characteristics are within ±10% of the indicated values of I_{sc} , V_{oc} and 0 to +5% of P_{max} (power measurement tolerance ±3%).

Electrical data (at NOCT)

		NU-R250J5	NU-R245J5	NU-R240J5	
Maximum power	P_{max}	179.9	176.3	172.7	W_p
Open-circuit voltage	V_{oc}	37.1	36.7	36.5	V
Short-circuit current	I_{sc}	7.07	7.05	6.96	A
Voltage at point of maximum power	V_{mpp}	27.9	27.4	27.1	V
Nominal Operating Cell Temperature	NOCT	47.5	47.5	47.5	°C

NOCT: Module operating temperature at 800 W/m² irradiance, air temperature of 20 °C, wind speed of 1 m/s.

Limit values

Maximum system voltage	1,000 V DC
Over-current protection	15 A
Temperature range	-40 to +90 °C
Maximum mechanical load	2,400 N/m ²

Mechanical data

Length	1,652 mm (+/-3.0 mm)
Width	994 mm (+/-2.0 mm)
Depth	46 mm (+/-0.8 mm)
Weight	19 kg

Temperature coefficient

P_{max}	-0.463 % / °C
V_{oc}	-0.330 % / °C
I_{sc}	+0.030 % / °C

Characteristic curves NU-R245J5

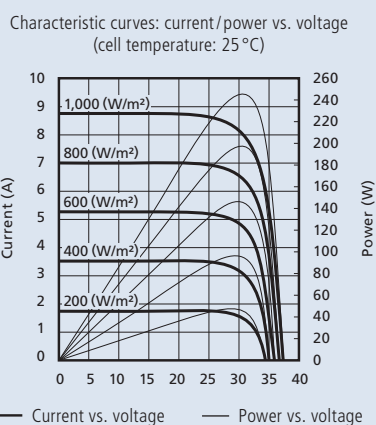

Rear view

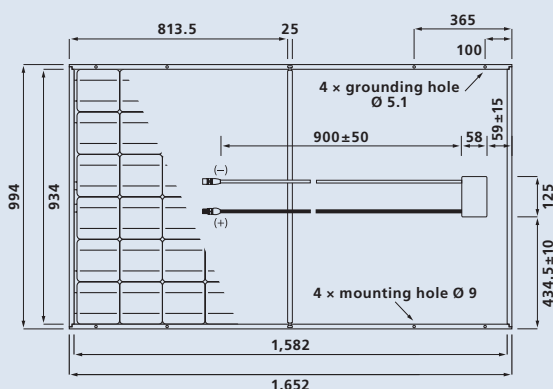

General data

Cells	monocrystalline, 156.5 mm × 156.5 mm, 60 cells in series
Front glass	low iron tempered glass, 3 mm
Frame	anodized aluminium alloy, silver
Connection box	PPE/PPO resin, IP65 rating, 58 × 125 × 15 mm, 3 bypass diodes
Cable	4 mm ² , length 900 mm
Connector	SMK (MC4 compatible), Type CCT9901-2361F/2451F (Catalogue no. P51-7H/R51-7), IP67 rating
To extend the module connection leads, only use SMK connector from the same series or MultiContactAG MC4 connector (PV-KST04/PV-KBT04)	

Registration

Sharp Solar guarantees the safety, quality and value of your product over many years – the only thing we ask you to do is to register your modules with the serial number, so that we can send you the guarantee certificate. Register your modules quickly and easily at www.brandaddedvalue.net.

Sharp Energy Solution Europe
 a division of Sharp Electronics (Europe) GmbH
 Sonninstrasse 3, 20097 Hamburg, Germany
 Tel: + 49 (0) 40 / 23 76 - 0 · Fax: + 49 (0) 40 / 23 76 - 21 93
www.sharp.eu/solar

Local responsibility:

Austria
SolarInfo.at@sharp.eu
Benelux
SolarInfo.seb@sharp.eu
Central & Eastern Europe
SolarInfo.scee@sharp.eu

Denmark
SolarInfo.dk@sharp.eu
France
SolarInfo.fr@sharp.eu
Germany
SolarInfo.de@sharp.eu

Scandinavia
SolarInfo.sen@sharp.eu
Spain & Portugal
SolarInfo.es@sharp.eu
Switzerland
SolarInfo.ch@sharp.eu
United Kingdom
SolarInfo.uk@sharp.eu

SHARP

The reference image on the front page shows a 33.88 kWp system in Northern Germany.
Note: Technical data is subject to change without prior notice. Before using Sharp products, please request the latest data sheets from Sharp. Sharp accepts no responsibility for damage to devices which have been equipped with Sharp products on the basis of unverified information. The specifications may deviate slightly and are not guaranteed. Installation and operating instructions are to be found in the corresponding handbooks, or can be downloaded from www.sharp.eu/solar. This module should not be directly connected to a load.